

Fleximount Rubber Isolator

Type FM



Also available in

NITRILE RUBBER

for higher Damping and longer life

LOAD / MOUNT : 80 - 1600 Kgs

DEFLECTION : upto 12 mm

DESIGN

Assembly consists of cast metal base and cover into which a pair of Rubber-to-metal bonded flexible units are sandwiched in an angular disposition. These are load in a combination of shear and compression for longest life and best load-deflection characteristics. They can not become solid and rendered ineffective.

THREE DEGREES OF FLEXIBILITY

Mountings are stiffer in the transverse direction as compared to flexibility in the horizontal direction. Mountings can be oriented to obtain greater flexibility in the required direction. When three or more mountings are arranged symmetrically around a vertical axis, the flexibility of the suspension is the same in all direction.

TYPICAL APPLICATIONS

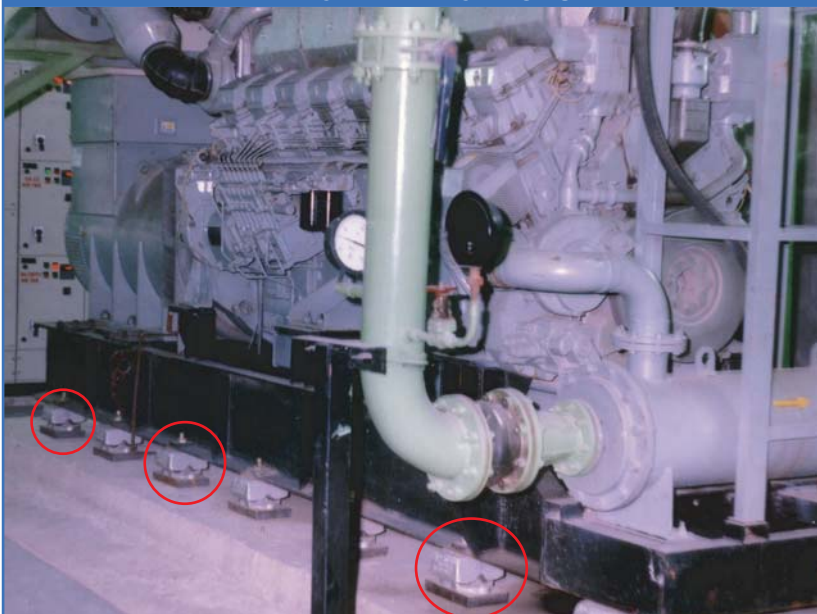

2000 KVA DG Set weighing 13,000 kgs mounted on 14 nos Fleximounts without foundation at Escorts Heart Centre

- No Grouting
- Instant Installation
- 60% Saving on foundation costs
- Upto 95% Vibration isolation
- 20% Noise reduction
- Fewer repairs and longer life of mounted equipment
- Accurate work and improvement in output efficiency
- Flexible Production lines

TYPICAL APPLICATIONS

- * CENTRIFUGALS
- * COMPRESSORS
- * CHAMBERS
- * DIESEL ENGINES
- * FANS
- * FURNACES
- * GENERATING SET
- * GRINDERS
- * PUMPS
- * POLISHING MACHINES
- * PRINTING MACHINE
- * TEXTILE MACHINES
- * VIBRATING SCREENS
- * WASHING MACHINES

RESISTOFLEX
SINCE 1947
Vibration Shock Seismic Control

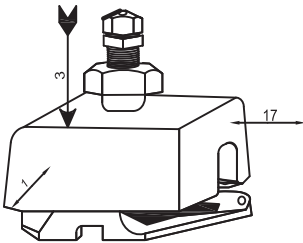
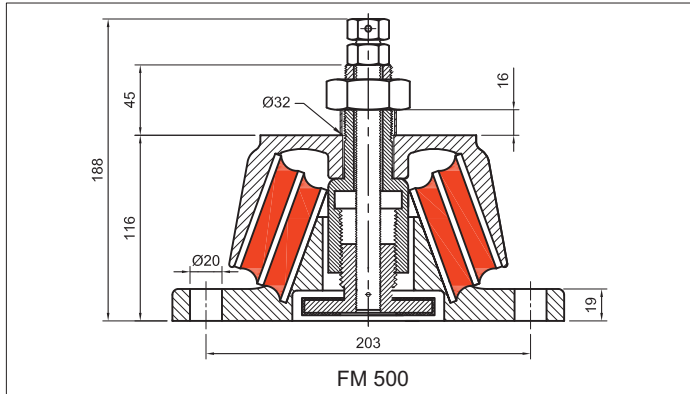
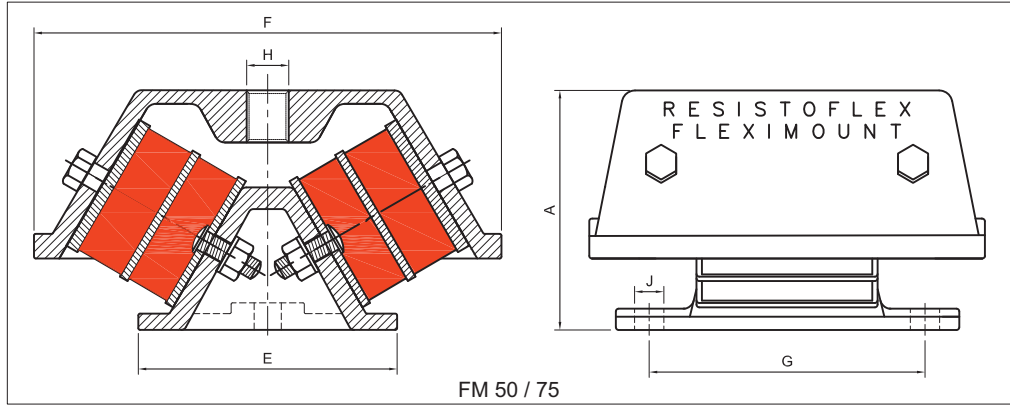

TECHNICAL CHARACTERISTICS

PART NO.	COLOUR CODE	RATED LOAD (kg)	DEFLECTION AT RATED LOAD $\pm 15\%$ (mm)	NOMINAL DIMENSIONS (mm)					
				A	E	F	G	H	J
FM-50A/40	BROWN	120	5.8	75	85	128	89	M12	11
FM-50A/50	PINK	160	6.2						
FM-50A/60	WHITE	240	5.8						
FM-50A/70	ORANGE	320	5.3						
FM-75X/40	BROWN	270	5.5	110	148	205	125	M16	17
FM-75X/50	PINK	380	5.5						
FM-75X/60	WHITE	480	5.5						
FM-75X/70	ORANGE	690	5.0						
FM-500S/40	BROWN	800	10.2	Please refer to sketch above					
FM-500S/50	PINK	1200	10.2						
FM-500S/60	WHITE	1600	10.3						

ACCESSORIES

Rubber Friction Pad made of oil resistant Nitrile Rubber obviate the necessity of bolting machine to floor. The pads locate the machine securely and overcome any tendency to "walk". No adhesives are required.

Levelling Device can be provided for machines requiring precision levelling.

MOUNTING SELECTION GUIDE

Disturbing Frequency	600	720	950	1250	1440	2000	2850
Isolation Efficiency (%)	70	70	70	75	80	85	90
Static Deflection (mm)	10.0	07.6	04.0	03.0	02.6	01.8	01.2

INSTALLATION MANUAL

Refer to IM 010 for detailed Installation Instructions

For more detailed information and technical assistance, please contact our Applications Engineering Group. In the interest of continual development and improvement, the company reserves the right to make modifications to these details without notice